

DAC4815

Quad 12-Bit Digital-to-Analog Converter (8-Bit Port Interface)

FEATURES

- COMPLETE QUAD DAC — INCLUDES INTERNAL REFERENCES AND OUTPUT AMPLIFIERS
- GUARANTEED SPECIFICATIONS OVER TEMPERATURE
- GUARANTEED MONOTONIC OVER TEMPERATURE
- HIGH-SPEED 8 + 4-BIT PARALLEL INTERFACE
- LOW POWER, 600mW (150mW/DAC)
- LOW GAIN DRIFT, 5ppm/°C
- LOW NONLINEARITY: $\pm 1/2$ LSB max
- BIPOLAR OUTPUT
- CLEAR/RESET TO BIPOLAR ZERO

DESCRIPTION

The DAC4815 is one in a family of dual and quad 12-bit digital-to-analog converters (DACs). Serial, 8-bit, 12-bit interfaces are available.

The DAC4815 is complete. It contains CMOS logic, switches, a high-performance buried-zener reference, and low-noise bipolar output amplifiers. No external components are required for bipolar $\pm 10V$ output range.

The DAC4815 has a 2-byte (8 + 4) double-buffered interface. Data is first loaded (level transferred) into the input registers in two steps for each DAC. Then both DACs are updated simultaneously. The DAC has an asynchronous clear control for reset to bipolar zero. This feature is useful for power-on reset or system calibration. The DAC4815 is packaged in a 28-pin plastic DIP rated for the $-40^{\circ}C$ to $+85^{\circ}C$ extended industrial temperature range.

High-stability laser-trimmed thin film resistors assure high reliability and true 12-bit integral and differential linearity over the full specified temperature range.

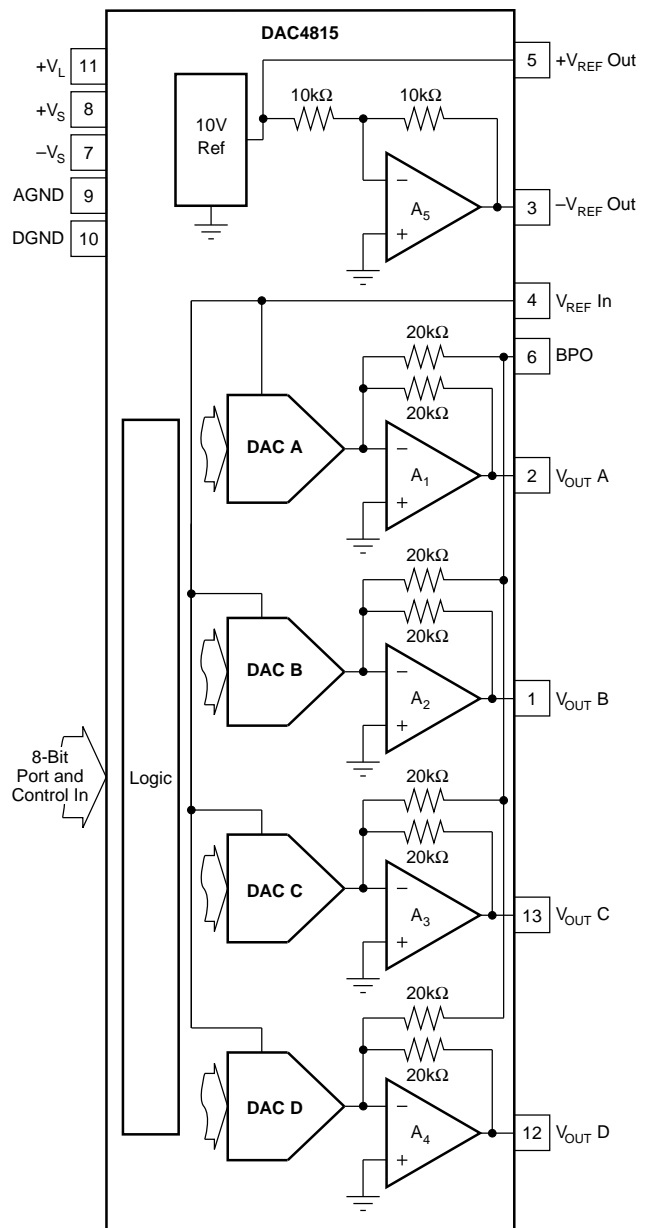

International Airport Industrial Park • Mailing Address: PO Box 11400 • Tucson, AZ 85734 • Street Address: 6730 S. Tucson Blvd. • Tucson, AZ 85706
Tel: (520) 746-1111 • Twx: 910-952-1111 • Cable: BBRCORP • Telex: 066-6491 • FAX: (520) 889-1510 • Immediate Product Info: (800) 548-6132

SPECIFICATIONS (CONT), Guaranteed over $T_A = -40^{\circ}\text{C}$ to $+85^{\circ}\text{C}$ unless otherwise specified.

ELECTRICAL

Specifications as shown for $V_S = \pm 12\text{V}$ or $\pm 15\text{V}$, $V_L = +5\text{V}$, and $R_L = 2\text{k}\Omega$ unless otherwise noted.

PARAMETER	CONDITIONS	DAC4815AP			DAC4815BP			UNITS
		MIN	TYP	MAX	MIN	TYP	MAX	
TEMPERATURE RANGE Specified Operating Thermal Resistance, θ_{JA}		-40		+85	*		*	$^{\circ}\text{C}$
		-40		+85	*		*	$^{\circ}\text{C}$
			75			*		$^{\circ}\text{C}/\text{W}$

NOTES: (1) End point linearity. (2) Guaranteed monotonic. (3) Change in bipolar full scale output. Includes effect of voltage output DAC, voltage references. (4) Guaranteed but not tested.

PIN DESIGNATIONS

PIN	DESCRIPTOR	FUNCTION	PIN	DESCRIPTOR	FUNCTION
1	$V_{OUT\ B}$	Analog output voltage, DAC B	28	A_2	Address line 2 input
2	$V_{OUT\ A}$	Analog output voltage, DAC A	27	A_1	Address line 1 input
3	$-V_{REF\ Out}$	Negative reference voltage output (-10V output)	26	A_0	Address line 0 input
4	$V_{REF\ In}$	\pm Reference voltage input	25	D_7	Data bit 7 input
5	$+V_{REF\ Out}$	Positive reference voltage output (+10V output)	24	D_6	Data bit 6 input
6	BPO	Bipolar offset input, DAC A, B, C, and D	23	D_5	Data bit 5 input
7	$-V_S$	Negative analog power supply, -15V input	22	D_4	Data bit 4 input
8	$+V_S$	Positive analog power supply, +15V input	21	D_3	Data bit 3 input
9	AGND	Analog common	20	D_2	Data bit 2 input
10	DGND	Digital common	19	D_1	Data bit 1 input
11	$+V_L$	Positive logic power supply, +5V input	18	D_0	Data bit 0 input
12	$V_{OUT\ D}$	Analog output voltage, DAC D	17	\overline{LE}	Latch data enable, DAC A, B, C, and D
13	$V_{OUT\ C}$	Analog output voltage, DAC C	16	\overline{CS}	Chip select enable, DAC A, B, C, and D
14	\overline{CLR}	Asynchronous input reset to zero	15	WR	Write input, DAC A, B, C, and D

PIN CONFIGURATIONS

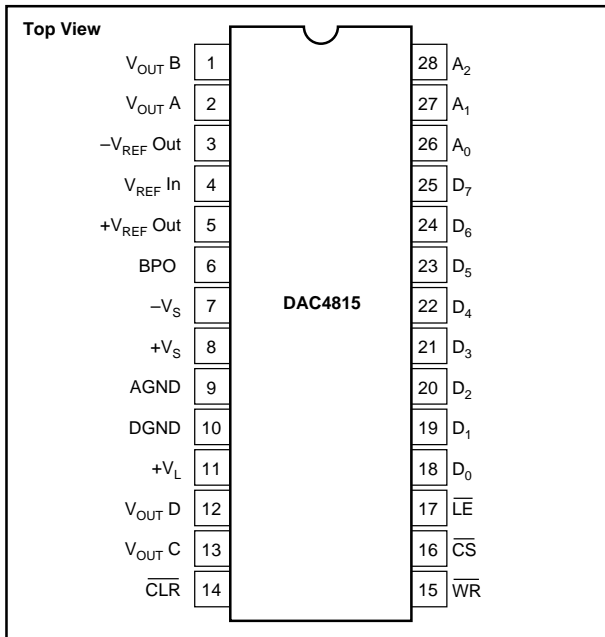

ABSOLUTE MAXIMUM RATINGS

$+V_L$ to AGND	0V, +7V
$+V_L$ to DGND	0V, +7V
$+V_S$ to AGND	0V, +18V
$-V_S$ to AGND	0V, -18V
AGND to DGND	$\pm 0.3\text{V}$
Any digital input to GND	-0.3V, $+V_L$ +0.3V
Ref In to AGND	$\pm 25\text{V}$
Ref In to DGND	$\pm 25\text{V}$
Storage Temperature Range	-55°C to $+125^{\circ}\text{C}$
Operating Temperature Range	-40°C to $+85^{\circ}\text{C}$
Lead Temperature (soldering, 10s)	$+300^{\circ}\text{C}$
Junction Temperature	$+155^{\circ}\text{C}$
Output Short Circuit	Continuous to common or $\pm V_S$
Reference Short Circuit	Continuous to common or $+V_S$

ELECTROSTATIC DISCHARGE SENSITIVITY

Electrostatic discharge can cause damage ranging from performance degradation to complete device failure. Burr-Brown Corporation recommends that all integrated circuits be handled and stored using appropriate ESD protection methods.

ORDERING INFORMATION

MODEL	LINEARITY ERROR (LSB)
DAC4815AP	± 1
DAC4815BP	$\pm 1/2$

PACKAGE INFORMATION

MODEL	PACKAGE	PACKAGE DRAWING NUMBER ⁽¹⁾
DAC4815AP	28-Pin Plastic DIP	215
DAC4815BP	28-Pin Plastic DIP	215

NOTE: (1) For detailed drawing and dimension table, please see end of data sheet, or Appendix D of Burr-Brown IC Data Book.

TYPICAL PERFORMANCE CURVES

$T_A = +25^\circ\text{C}$, $V_S = \pm 12\text{V}$ or $\pm 15\text{V}$, $V_L = +5\text{V}$ unless otherwise noted.

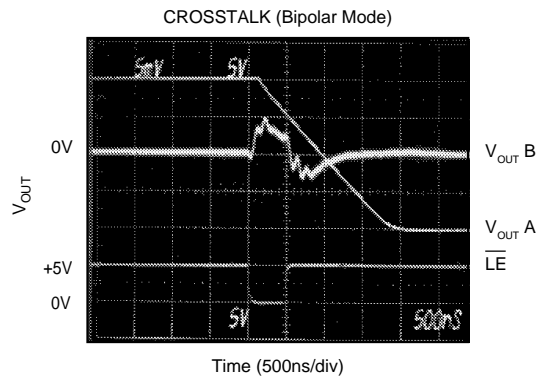
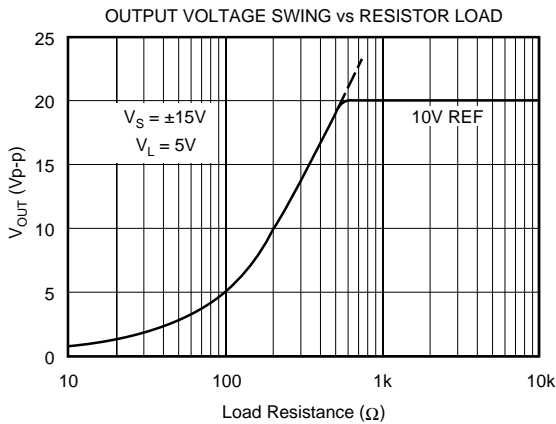
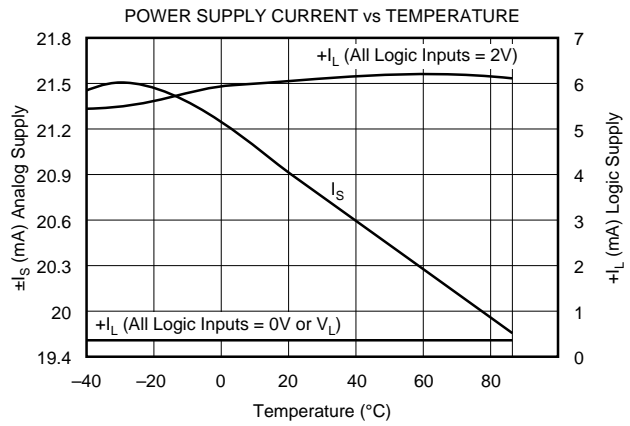
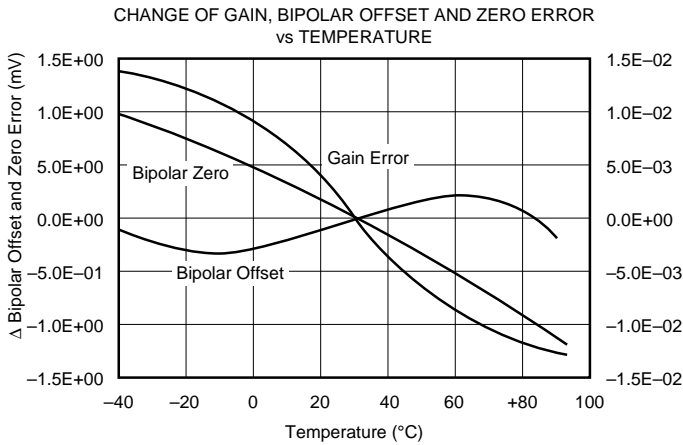
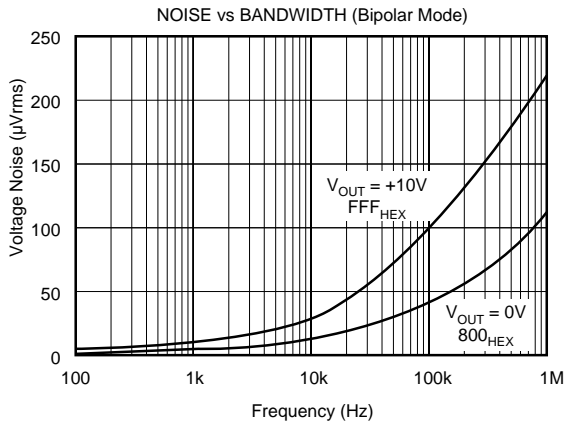
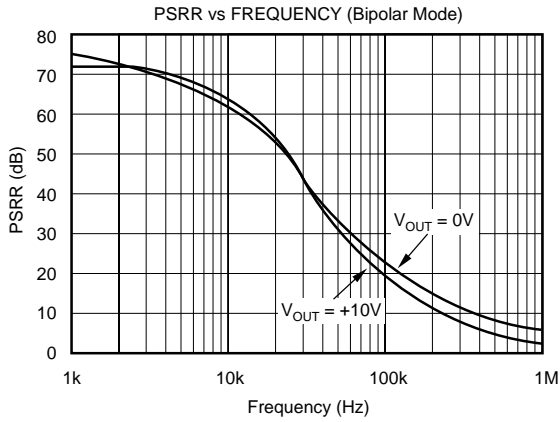

NOTE: Crosstalk is dominated by digital crosstalk/feedthrough of \overline{LE} signal.

TYPICAL PERFORMANCE CURVES (CONT)

$T_A = +25^\circ\text{C}$, $V_S = \pm 12\text{V}$ or $\pm 15\text{V}$, $V_L = +5\text{V}$ unless otherwise noted.

FULL-SCALE OUTPUT SWING
BIPOLAR (20V Step)

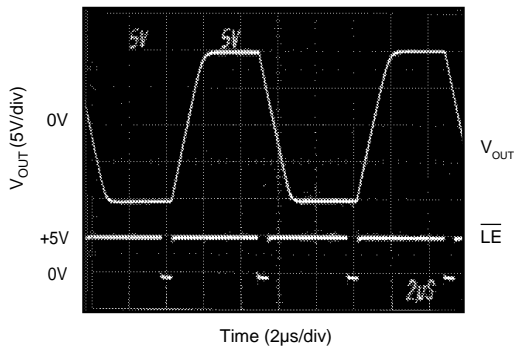

SETTLING TIME
BIPOLAR (-10V to +10V)

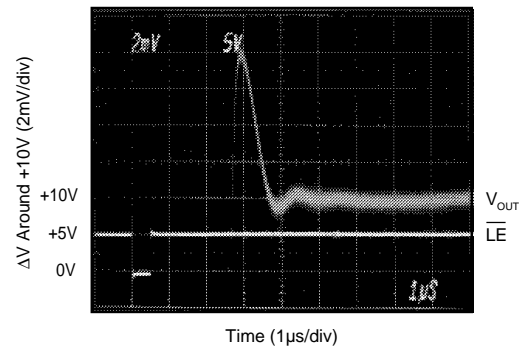

SETTLING TIME
BIPOLAR (+10V to -10V Step)

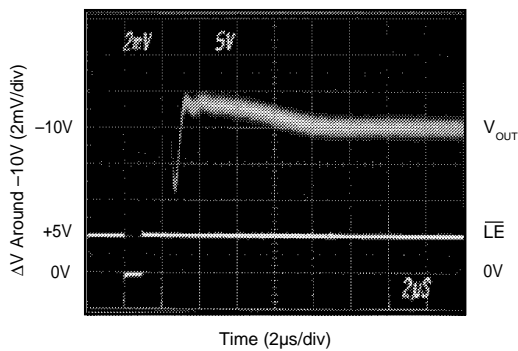

MAJOR CARRY GLITCH

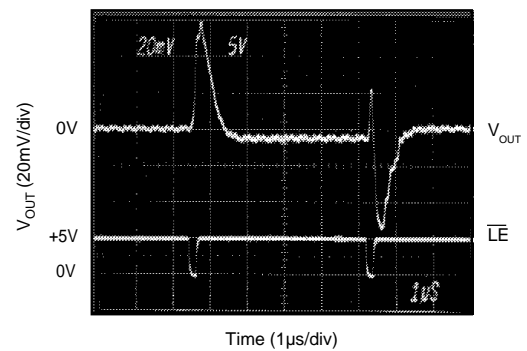

NOTE: Data transition 800_{HEX} to 7FF_{HEX}.

DIGITAL FEEDTHROUGH

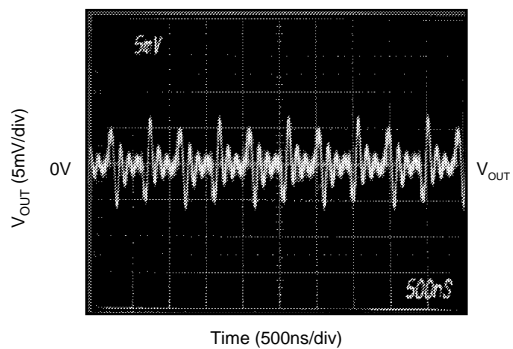

DAC output noise due to activity on digital inputs with latch disabled.

FUNCTIONAL BLOCK DIAGRAM, DAC4815 — Quad 12-bit DAC, 8-bit Port

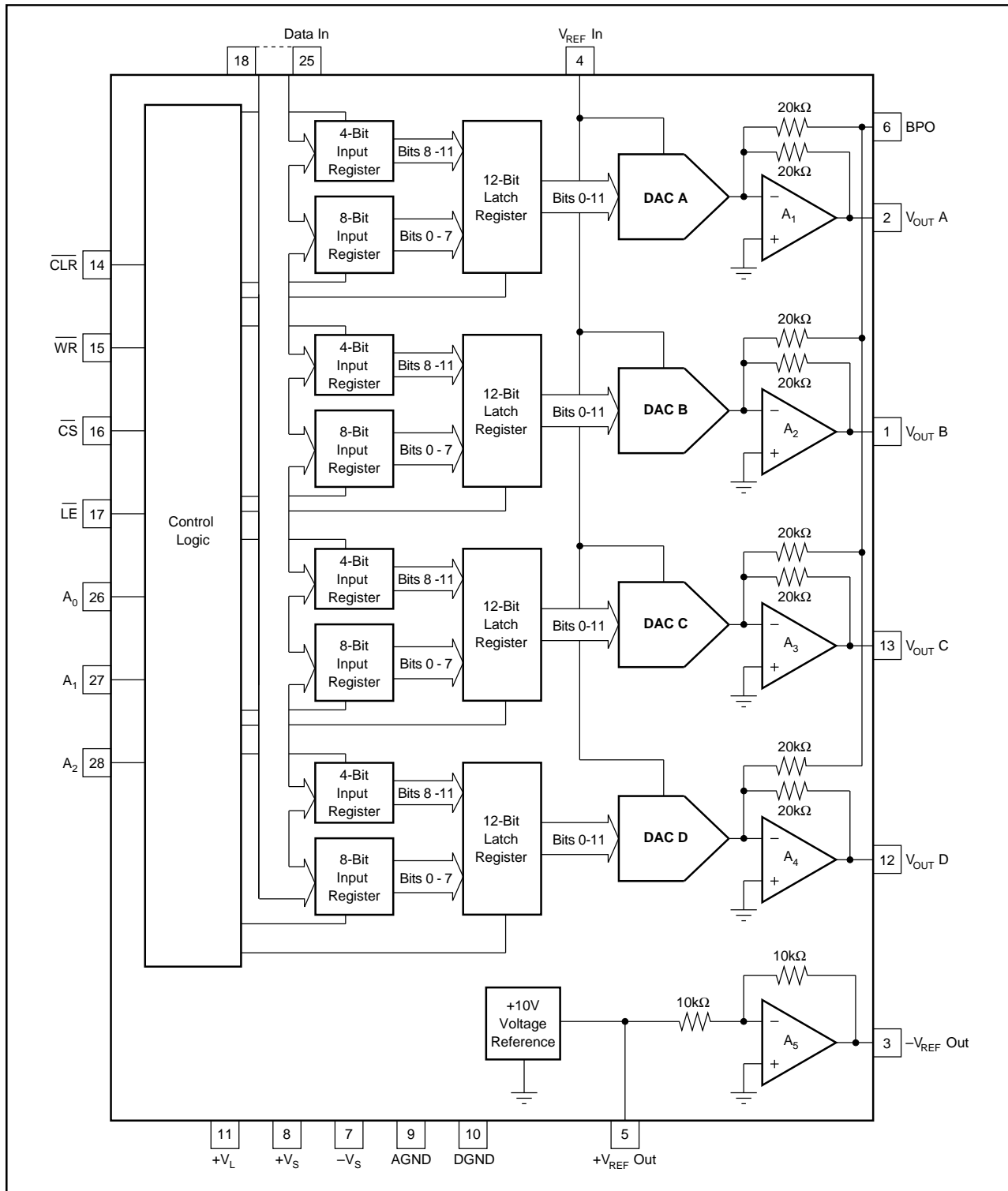

TIMING CHARACTERISTICS

+V_L = +5V, T_A = -40°C to +85°C.

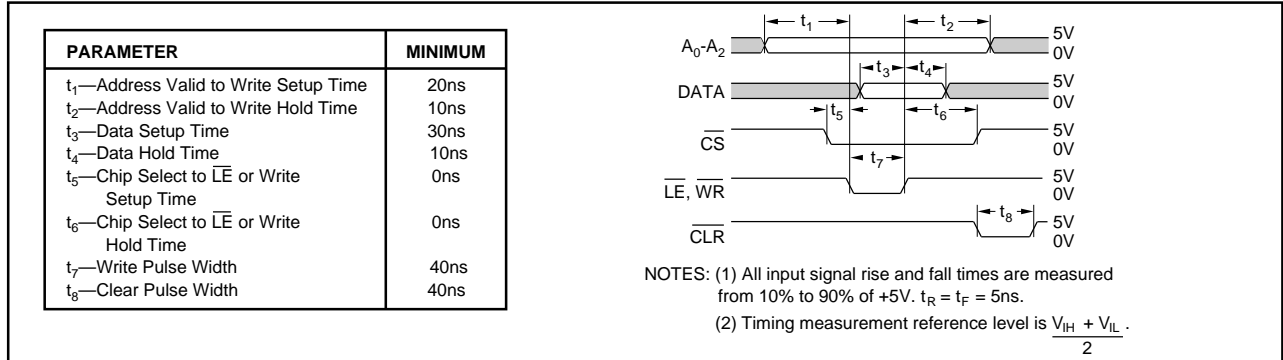

INTERFACE LOGIC TRUTH TABLE

CLR	\overline{LE}	\overline{CS}	WR	A ₂	A ₁	A ₀	FUNCTION
1	1	0	0	0	0	0	DAC A LS input register loaded with D7-D0(LSB)
1	1	0	0	0	0	1	DAC A MS input register loaded with D3(MSB)-D0
1	1	0	0	0	1	0	DAC B LS input register loaded with D7-D0(LSB)
1	1	0	0	0	1	1	DAC B MS input register loaded with D3(MSB)-D0
1	1	0	0	1	0	0	DAC C LS input register loaded with D7-D0(LSB)
1	1	0	0	1	0	1	DAC C MS input register loaded with D3(MSB)-D0
1	1	0	0	1	1	0	DAC D LS input register loaded with D7-D0(LSB)
1	1	0	0	1	1	1	DAC D MS input register loaded with D3(MSB)-D0
1	0	0	1	X	X	X	All DAC registers updated simultaneously from input registers
1	0	0	0	X	X	X	All DAC registers are transparent
1	X	1	X	X	X	X	No data transfer
1	1	X	1	X	X	X	No data transfer
0	X	X	X	X	X	X	Input registers cleared = 000 _{HEX} , DAC registers = 800 _{HEX}

NOTE: X = Don't care.

DISCUSSION OF SPECIFICATIONS

INPUT CODES

All digital inputs of the DAC4815 are TTL and 5V CMOS compatible. Input codes for the DAC4815 are BOB (Bipolar Offset Binary). See Figure 3 for ±10V bipolar connection.

BIPOLAR OUTPUTS FOR SELECTED INPUT

DIGITAL INPUT	BIPOLAR (BOB)
FFF _{HEX}	+Full Scale
800 _{HEX}	Zero
7FF _{HEX}	Zero - 1 LSB
000 _{HEX}	-Full Scale

INTEGRAL OR RELATIVE LINEARITY

This term, also known as end point linearity, describes the transfer function of analog output to digital input code. Integral linearity error is the deviation of the analog output versus code transfer function from a straight line drawn through the end points.

DIFFERENTIAL NONLINEARITY

Differential nonlinearity is the deviation from an ideal 1 LSB change in the output voltage when the input code changes by 1 LSB. A differential nonlinearity specification of ±1 LSB maximum guarantees monotonicity.

BIPOLAR ZERO ERROR

The output voltage for code 800_{HEX}.

GAIN ERROR

The deviation of the output voltage span (V_{MAX} - V_{MIN}) from the ideal span of 20V - 1 LSB (bipolar mode). The gain error is specified with and without the internal +10V reference error included.

OUTPUT SETTLING TIME

The time required for the output voltage to settle within a percentage-of-full-scale error band for a full scale transition. Settling to ±0.012% (1/2 LSB) is specified for the DAC4815.

DIGITAL-TO-ANALOG GLITCH

Ideally, the DAC output would make a clean step change in response to an input code change. In reality, glitches occur during the transition. See Typical Performance Curves.

DIGITAL CROSSTALK

Digital crosstalk is the glitch impulse measured at the output of one DAC due to a full scale transition on the other DAC—see Typical Performance Curves. It is dominated by digital coupling. Also, the integrated area of the glitch pulse is specified in nV-s. See table of electrical specifications.

DIGITAL FEEDTHROUGH

Digital feedthrough is the noise at a DAC output due to activity on the digital inputs—see Typical Performance Curves.

OPERATION

Depending on the address selected, the 4 MSBs or the 8 LSBs are written into the appropriate input register for each DAC when the \overline{WR} signal is brought low. The data are latched in the input register when the \overline{WR} goes high. Data are then transferred from the input registers to the DAC latch registers by bringing \overline{LE} low. The data are latched in the DAC latch registers when \overline{LE} goes high. All DACs are updated simultaneously.

When \overline{CLR} is brought low, the input registers are cleared to 000_{HEX} while the DAC registers = 800_{HEX} . If \overline{LE} is brought low after \overline{CLR} the DACs are updated with 000_{HEX} resulting in -10V (bipolar) or 0V (unipolar) on the output.

CIRCUIT DESCRIPTION

Each of the four DACs in the DAC4815 consists of a CMOS logic section, a CMOS DAC cell, and an output amplifier. One buried-zener $+10.0\text{V}$ reference and a -10V reference are shared by all DACs.

Figure 1 is a simplified circuit for a DAC cell. An R , $2R$ ladder network is driven by a voltage reference at V_{REF} . Current from the ladder is switched either to I_{OUT} or AGND by 12 single-pole double-throw CMOS switches. This maintains constant current in each leg of the ladder regardless of digital input code. This makes the resistance at V_{REF} constant (it can be driven by either a voltage or current reference). The reference can be either positive or negative polarity with a range of up to $\pm 10\text{V}$.

CMOS switches included in series with the ladder terminating resistor and the feedback resistor, R_{FB} , compensate for the temperature drift of the ladder switch ON resistance.

The output op amps are connected as transimpedance amplifiers to convert the DAC-cell output current into an output voltage. They have been specially designed and compensated for precision and fast settling in this application.

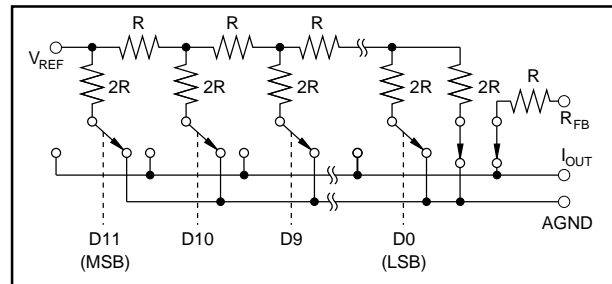

FIGURE 1. Simplified Circuit Diagram of DAC Cell.

POWER SUPPLY CONNECTIONS

The DAC4815 is specified for operation with power supplies of $V_L = +5\text{V}$ and $V_S = \text{either } \pm 12\text{V} \text{ or } \pm 15\text{V}$. Even with the V_S supplies at $\pm 11.4\text{V}$ the DACs can swing a full $\pm 10\text{V}$. Power supply decoupling capacitors ($1\mu\text{F}$ tantalum) should be located close to the DAC power supply connections.

Separate digital and analog ground pins are provided to permit separate current returns. They should be connected together at one point. Proper layout of the two current returns will prevent digital logic switching currents from degrading the analog output signal. The analog ground current is code dependent so the impedance to the system reference ground must be kept to a minimum. Connect DACs as shown in Figure 2 or use a ground plane to keep ground impedance less than 0.1Ω for less than 0.1LSB error.

$\pm 10\text{V}$ OUTPUT RANGE CONNECTION

For a $\pm 10\text{V}$ bipolar output connect the DAC4815 as shown in Figure 3.

CONNECTION TO DIGITAL BUS

DAC4815s can easily be connected to a μ processor bus. Decode your address lines to derive the control signals shown in Figure 4. Only one LATCH signal is required for a system where all DAC4815s are updated simultaneously. If you want to update DAC4815s independently, use separate LATCH signals. The LATCH and WRITE signals can be brought low simultaneously to update the DAC registers with the same processor instruction that writes the final 8-bit data word the DAC input registers.

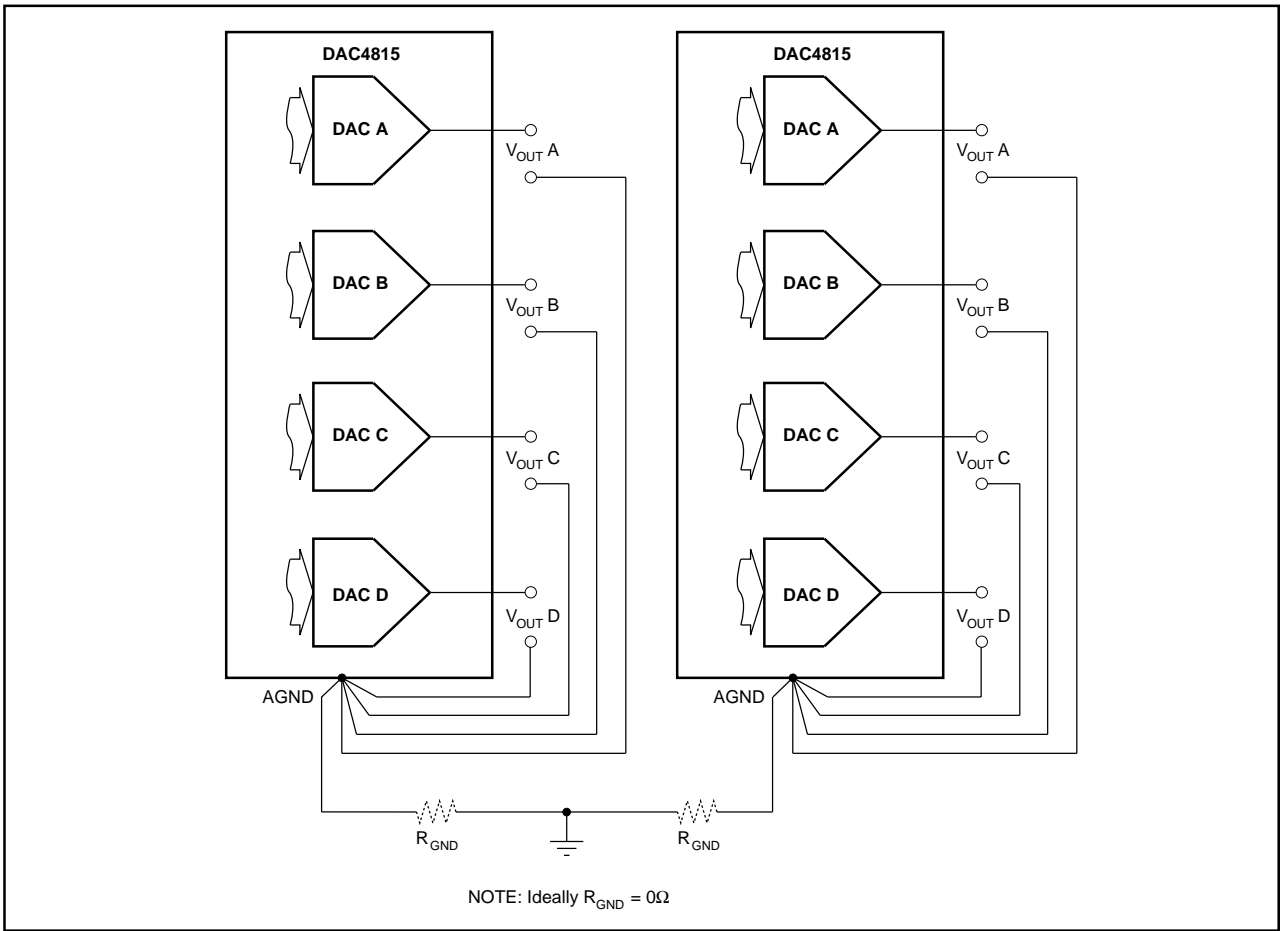

FIGURE 2. Recommended Ground Connections for Multiple DAC Packages.

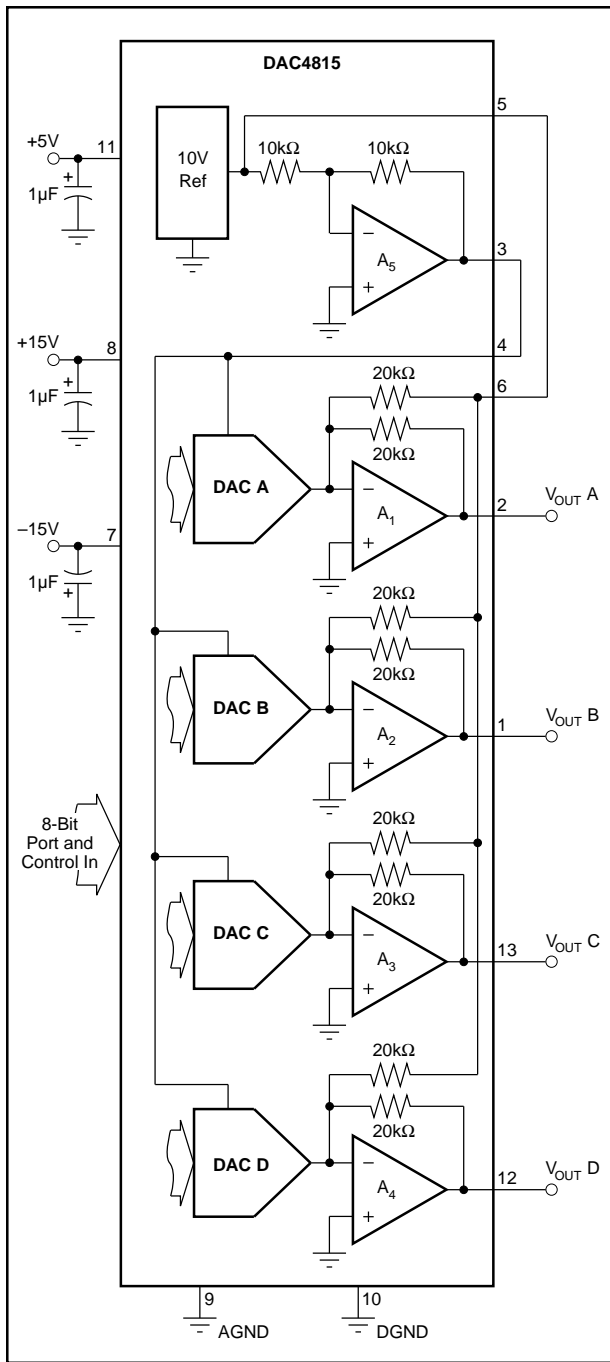

FIGURE 3. Analog Connections for $\pm 10V$ DAC Output.

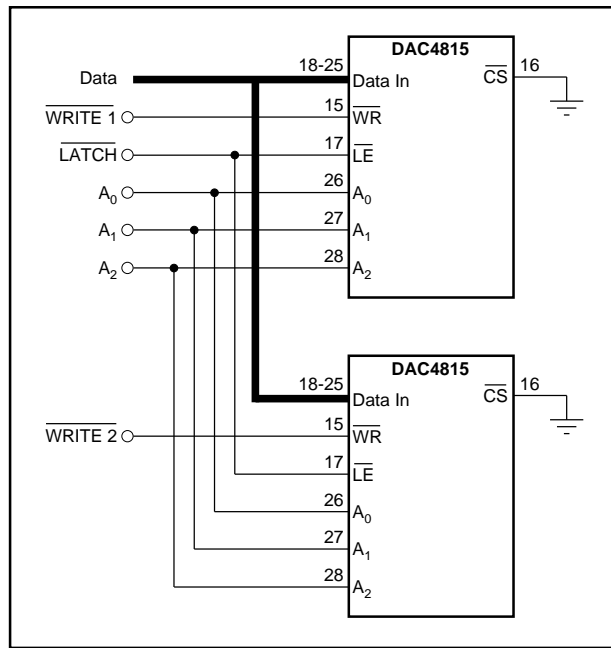

FIGURE 4. Logic Connections for Multiple DAC4815 Packages.

The information provided herein is believed to be reliable; however, BURR-BROWN assumes no responsibility for inaccuracies or omissions. BURR-BROWN assumes no responsibility for the use of this information, and all use of such information shall be entirely at the user's own risk. Prices and specifications are subject to change without notice. No patent rights or licenses to any of the circuits described herein are implied or granted to any third party. BURR-BROWN does not authorize or warrant any BURR-BROWN product for use in life support devices and/or systems.

PACKAGING INFORMATION

Orderable Device	Status ⁽¹⁾	Package Type	Package Drawing	Pins	Package Qty	Eco Plan ⁽²⁾	Lead/Ball Finish	MSL Peak Temp ⁽³⁾
DAC4815AP	OBSOLETE	PDIP	NTD	28		None	Call TI	Call TI
DAC4815BP	OBSOLETE	PDIP	NTD	28		None	Call TI	Call TI

⁽¹⁾ The marketing status values are defined as follows:

ACTIVE: Product device recommended for new designs.

LIFEBUY: TI has announced that the device will be discontinued, and a lifetime-buy period is in effect.

NRND: Not recommended for new designs. Device is in production to support existing customers, but TI does not recommend using this part in a new design.

PREVIEW: Device has been announced but is not in production. Samples may or may not be available.

OBSOLETE: TI has discontinued the production of the device.

⁽²⁾ Eco Plan - May not be currently available - please check <http://www.ti.com/productcontent> for the latest availability information and additional product content details.

None: Not yet available Lead (Pb-Free).

Pb-Free (RoHS): TI's terms "Lead-Free" or "Pb-Free" mean semiconductor products that are compatible with the current RoHS requirements for all 6 substances, including the requirement that lead not exceed 0.1% by weight in homogeneous materials. Where designed to be soldered at high temperatures, TI Pb-Free products are suitable for use in specified lead-free processes.

Green (RoHS & no Sb/Br): TI defines "Green" to mean "Pb-Free" and in addition, uses package materials that do not contain halogens, including bromine (Br) or antimony (Sb) above 0.1% of total product weight.

⁽³⁾ MSL, Peak Temp. -- The Moisture Sensitivity Level rating according to the JEDEC industry standard classifications, and peak solder temperature.

Important Information and Disclaimer: The information provided on this page represents TI's knowledge and belief as of the date that it is provided. TI bases its knowledge and belief on information provided by third parties, and makes no representation or warranty as to the accuracy of such information. Efforts are underway to better integrate information from third parties. TI has taken and continues to take reasonable steps to provide representative and accurate information but may not have conducted destructive testing or chemical analysis on incoming materials and chemicals. TI and TI suppliers consider certain information to be proprietary, and thus CAS numbers and other limited information may not be available for release.

In no event shall TI's liability arising out of such information exceed the total purchase price of the TI part(s) at issue in this document sold by TI to Customer on an annual basis.

IMPORTANT NOTICE

Texas Instruments Incorporated and its subsidiaries (TI) reserve the right to make corrections, modifications, enhancements, improvements, and other changes to its products and services at any time and to discontinue any product or service without notice. Customers should obtain the latest relevant information before placing orders and should verify that such information is current and complete. All products are sold subject to TI's terms and conditions of sale supplied at the time of order acknowledgment.

TI warrants performance of its hardware products to the specifications applicable at the time of sale in accordance with TI's standard warranty. Testing and other quality control techniques are used to the extent TI deems necessary to support this warranty. Except where mandated by government requirements, testing of all parameters of each product is not necessarily performed.

TI assumes no liability for applications assistance or customer product design. Customers are responsible for their products and applications using TI components. To minimize the risks associated with customer products and applications, customers should provide adequate design and operating safeguards.

TI does not warrant or represent that any license, either express or implied, is granted under any TI patent right, copyright, mask work right, or other TI intellectual property right relating to any combination, machine, or process in which TI products or services are used. Information published by TI regarding third-party products or services does not constitute a license from TI to use such products or services or a warranty or endorsement thereof. Use of such information may require a license from a third party under the patents or other intellectual property of the third party, or a license from TI under the patents or other intellectual property of TI.

Reproduction of information in TI data books or data sheets is permissible only if reproduction is without alteration and is accompanied by all associated warranties, conditions, limitations, and notices. Reproduction of this information with alteration is an unfair and deceptive business practice. TI is not responsible or liable for such altered documentation.

Resale of TI products or services with statements different from or beyond the parameters stated by TI for that product or service voids all express and any implied warranties for the associated TI product or service and is an unfair and deceptive business practice. TI is not responsible or liable for any such statements.

Following are URLs where you can obtain information on other Texas Instruments products and application solutions:

Products		Applications	
Amplifiers	amplifier.ti.com	Audio	www.ti.com/audio
Data Converters	dataconverter.ti.com	Automotive	www.ti.com/automotive
DSP	dsp.ti.com	Broadband	www.ti.com/broadband
Interface	interface.ti.com	Digital Control	www.ti.com/digitalcontrol
Logic	logic.ti.com	Military	www.ti.com/military
Power Mgmt	power.ti.com	Optical Networking	www.ti.com/opticalnetwork
Microcontrollers	microcontroller.ti.com	Security	www.ti.com/security
		Telephony	www.ti.com/telephony
		Video & Imaging	www.ti.com/video
		Wireless	www.ti.com/wireless

Mailing Address: Texas Instruments
Post Office Box 655303 Dallas, Texas 75265